



www.myeyeinthesky.com

## Installation manual for Fleet Units 600 series to Unit serial no's 600 to 625

Each unit is marked 12v or 24v pending on the assets voltage be sure to match the correct unit voltage to the asset voltage

Our staff will activate the unit and setup your tracking portal internet access

**PLEASE NOTE: GPS FLEET UNITS MUST BE INSTALLED BY A LICENCED AUTO ELECTRICIAN IN ORDER TO RETAIN ALL WARRENTIES BY THE MANUFACTURES. FAILURE TO DO SO WILL RESULT IN TERMINATION OF ALL WARRANTIES OR REFUNDS.**

The following diagram shows the wiring loom harness and its related connectors.

### WIRING LOOM CONNECTOR FOR 600 SERIES FLEET UNIT

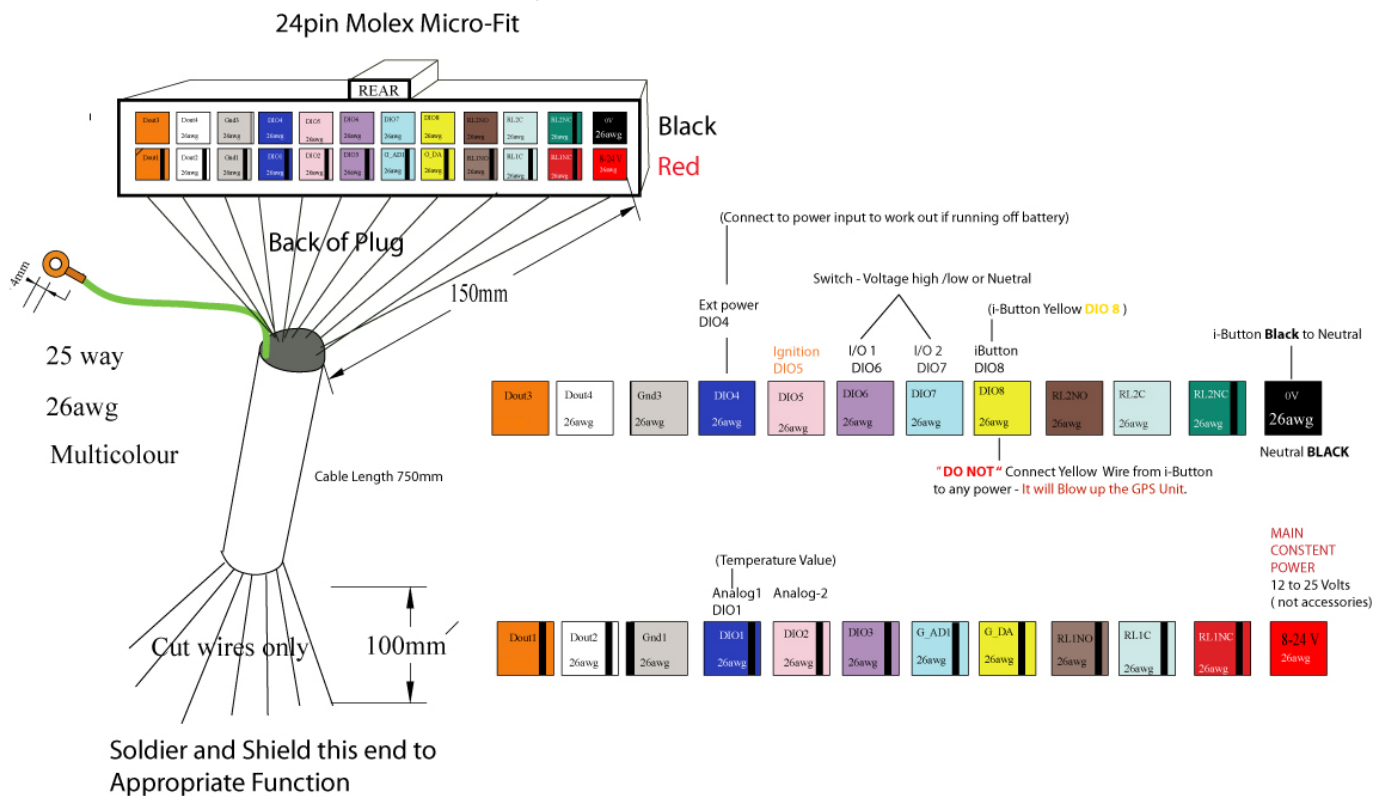

**. DO NOT OPEN THE TRACKING DEVICE CASE UNDER ANY CIRCUMSTANCES**

There is no need to open the case, if the QA stickers are broken, all warranties will be void.

**2. USE THE CORRECT COLOUR COMBINATION as in the above diagram - (DO NOT connect IGNITION Wire to ACCESSORIES.)**

In order to keep all installations universal for easy replacements at a later date, please use the good quality connectors throughout your installations of your units. (Be sure to make notes on the type of connectors and procedures used)

**3. MOUNT IN A COOL DRY PLACE OUT OF DIRECT SUNLIGHT, PREFERABLY BELOW 35C**

The Units have an operating temperature of 0-50C but the internal Lithium Ion battery will not commence charging unless the temperature is below 35C so it is imperative that the unit be **mounted well away from engine heat or the vehicle's heaters And kept out of direct sunlight**. It is also recommended that the Units case does not make direct contact other metal surface that could have a direct contact with sunlight, as heat will be transferred to the Unit in this way.

The Unit has a temperature monitor inbuilt that will send an E-Mail alert to the administrator when the temperature rises above 60C indicating that the unit may have to be relocated.

**For trouble free installs --** We recommend the GPS Unit be installed in the dash with the GPS and GPRS antennas providing they can be placed in other suitable locations that has a direction up to the sky . The signal will travel through plastics, glass , fiber glass BUT NOT some ferrous materials like steel or iron

**4. MAKE SURE THE GPS ANTENNA HAS A GOOD VIEW OF THE SKY**

The Unit is fitted with a super sensitive GPS module but for reliable operation, the GPS antenna should have at least a 60-degree view of the sky. The GPS antenna will work through glass and plastics **but not metals**. Also, care must be taken to ensure the antenna cable does not get crimped between doors etc as this type of damage will not be covered under the warranty.

**5. MAKE SURE GPRS ANTENNA HAS A GOOD VIEW OF THE SKY**

The location of the GPRS antenna is not as critical as the GPS antenna but for optimum operation mount as far away from metal surfaces as possible and again take care that the antenna cable will not be crimped between doors etc as this type of damage will not be covered under the warranty.

**6. DO NOT CONNECT IBUTTON WIRE TO DC VOLTAGE**

If hooking up the optional iButton, please use the supplied iButton socket with a maximum cable length of 10 meters between the socket and the Units connector. The center pin of the socket goes to the iButton wire on the Units connector ( see above diagram) and the outer wire needs to be connected to ground as close as possible to the Unit. **The iButton wire must not be connected to any DC voltage** or permanent damage can occur to the Unit . This will not be covered under warranties.

**7/ INPUTS 1 or In2 /Output - Is an option feature that – MEASURES FOATING, HIGH OR LOW VOLTAGE**

If hooking up the option - IN PUT 1 or 2 Use your Multi Meter to test voltage change .when switching off or on.

In-Puts can be used to trigger a multiple of various events. For Example. Open & Close Doors Switches, Use of Hydraulic Pumps, Damper switches, ON/OFF Switches, Temperature Alert Switches. ( Power take-off Diagram ) Can be connected to light indicators.

8/ Temperature sensors that measure temperature in trailers or refrigerated trucks and cargo are connected to the inputs ( see wiring diagram )

**9. START THE VEHICLE CHECK LED STATUS ONCE INSTALATION COMPLETE**

Once the installation is complete, it is advisable to start the vehicle for a few seconds to ensure that the Unit is awake, Once it is awake, the LED should glow bright. Each LED will alert you by a series of flashings and solid state events- see below



**LEFT ORANGE** Goes from solid while starting up to 1 sec on / 1 sec off while system is powered up and running normally



**MIDDLE GREEN** Goes on solid then GPS is acquired, other wise OFF  
**GREEN S2** Should flash if the GPS is operating but it has not acquiring a position



**RIGHT RED** Solid Red - Network connected to server is established  
**RED S3** Flash Red - While the unit is charging internal battery or trying to connect to the network but has not connected.

# Circuit Input for Input 1 & 2

Power Take Off Diagram (typical earth moving)

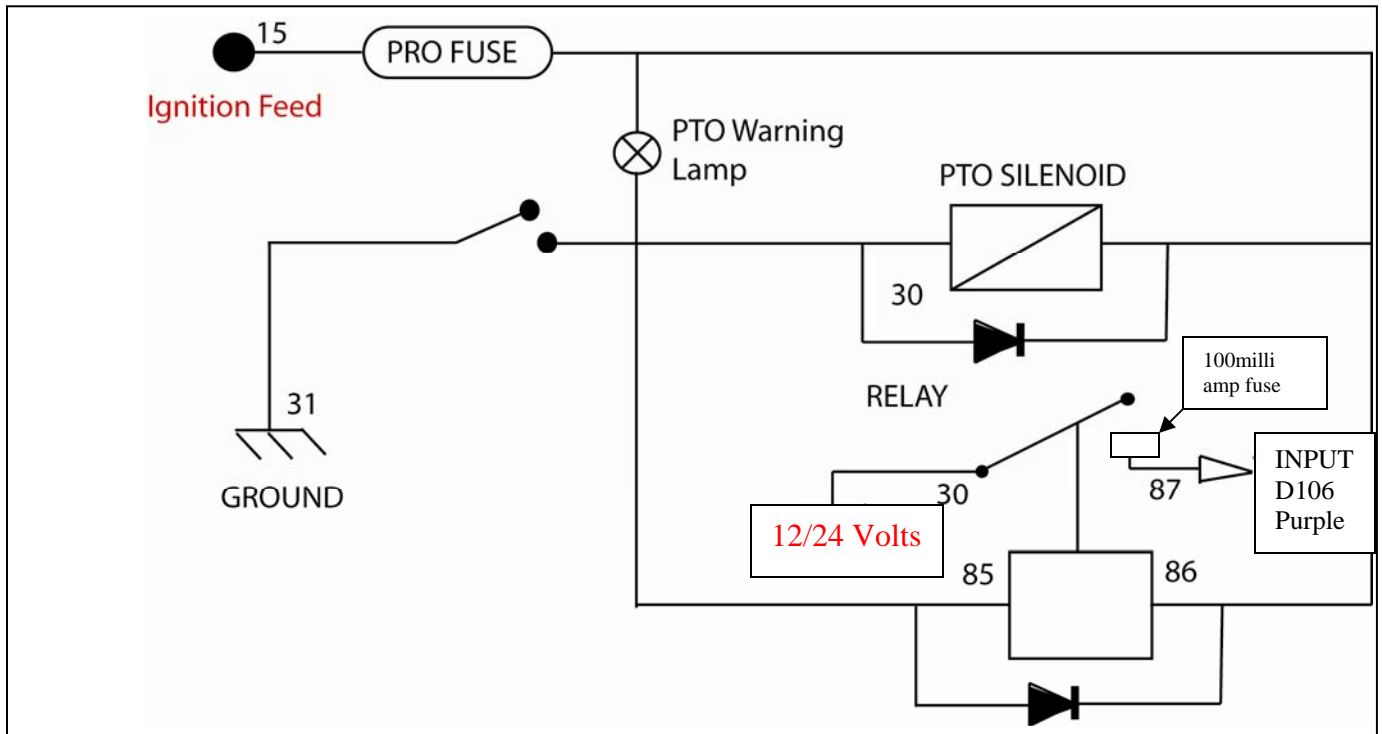

## Installation Instructions for Identification Button (i-Button)

**DO NOT connect grey wire to power at any time**

The i-Button is used to identify operators or users of various assets.  
Once the Key comes in contact with the Button a Unique Code is logged.

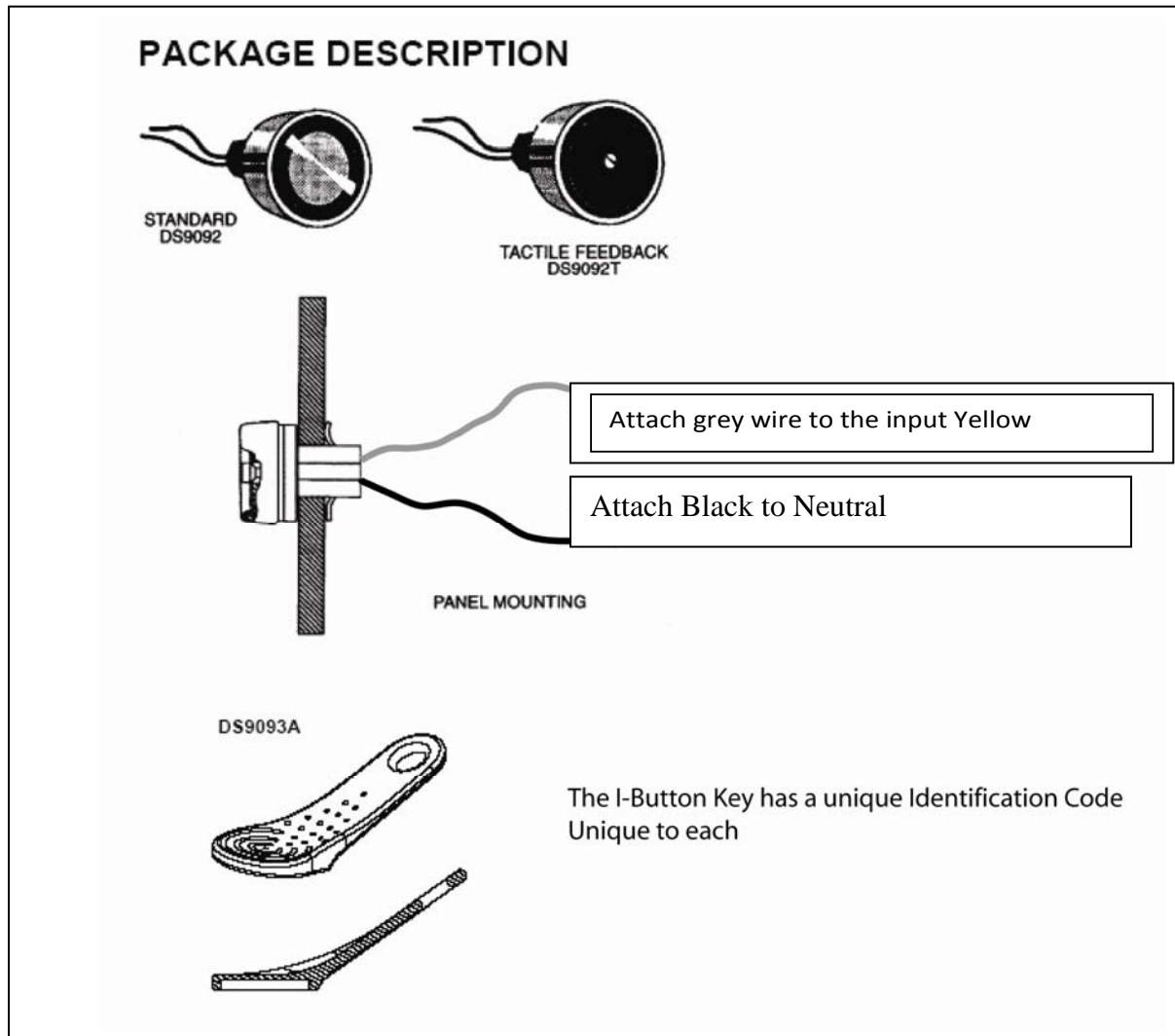

**Be shore to TEST the I-Button once the installation is complete.**

The ID code is send remotely to the server via GPRS. It is important to Test that the information has been delivered.

Temperature sensor diagram

